

Instructions



067-0484-02
Deskew Fixture
071-7022-02

Warning

The servicing instructions are for use by qualified personnel only. To avoid personal injury, do not perform any servicing unless you are qualified to do so. Refer to all safety summaries prior to performing service.

www.tektronix.com



071702202

Copyright © Tektronix, Inc. All rights reserved.

Tektronix products are covered by U.S. and foreign patents, issued and pending. Information in this publication supercedes that in all previously published material. Specifications and price change privileges reserved.

Tektronix, Inc., P.O. Box 500, Beaverton, OR 97077

TEKTRONIX and TEK are registered trademarks of Tektronix, Inc.

Table of Contents

General Safety Summary	iii
Service Safety Summary	v
Contacting Tektronix	vi
Deskew and Gain Cal Fixture Instructions	1
Overview	1
Specifications	2
Powering the Deskew Fixture for Skew Adjust	2
Connecting Probes to the Deskew Fixture	3
Load balancing when deskewing a differential probe with a single-ended probe	10
Using the Deskew Fixture to deskew channels	12
Connecting to the Gain Cal Fixture	14
Using the Deskew Fixture to Gain Cal	18

Mechanical Parts List

Mechanical Parts Lists	21
------------------------------	----

General Safety Summary

Review the following safety precautions to avoid injury and prevent damage to this product or any products connected to it. To avoid potential hazards, use this product only as specified.

Only qualified personnel should perform service procedures.

While using this product, you may need to access other parts of the system. Read the *General Safety Summary* in other system manuals for warnings and cautions related to operating the system.

Observe All Terminal Ratings. To avoid fire or shock hazard, observe all ratings and markings on the product. Consult the product manual for further ratings information before making connections to the product.

Use Proper Fuse. Use only the fuse type and rating specified for this product.

Avoid Exposed Circuitry. Do not touch exposed connections and components when power is present.

Do Not Operate With Suspected Failures. If you suspect there is damage to this product, have it inspected by qualified service personnel.

Do Not Operate in Wet/Damp Conditions.

Do Not Operate in an Explosive Atmosphere.

Keep Product Surfaces Clean and Dry.

Symbols and Terms

Terms in this Manual. These terms may appear in this manual:



WARNING. Warning statements identify conditions or practices that could result in injury or loss of life.



CAUTION. Caution statements identify conditions or practices that could result in damage to this product or other property.

Symbols on the Product. The following symbols may appear on the product:



CAUTION
Refer to Manual



Protective Ground
(Earth) Terminal

Service Safety Summary

Only qualified personnel should perform service procedures. Read this *Service Safety Summary* and the *General Safety Summary* before performing any service procedures.

Do Not Service Alone. Do not perform internal service or adjustments of this product unless another person capable of rendering first aid and resuscitation is present.

Disconnect Power. To avoid electric shock, switch off the instrument power, then disconnect the power cord from the mains power.

Use Care When Servicing With Power On. Dangerous voltages or currents may exist in this product. Disconnect power, remove battery (if applicable), and disconnect test leads before removing protective panels, soldering, or replacing components.

To avoid electric shock, do not touch exposed connections.

Contacting Tektronix

Phone	1-800-833-9200*
Address	Tektronix, Inc. Department or name (if known) 14200 SW Karl Braun Drive P.O. Box 500 Beaverton, OR 97077 USA
Web site	www.tektronix.com
Sales support	1-800-833-9200, select option 1*
Service support	1-800-833-9200, select option 2*
Technical support	www.tektronix.com/support 1-800-833-9200, select option 3* 6:00 a.m. - 5:00 p.m. Pacific Standard Time

* **This phone number is toll free in North America. After office hours, please leave a voice mail message. Outside North America, contact a Tektronix sales office or distributor; see the Tektronix web site for a list of offices.**

Deskew and Gain Cal Fixture Instructions

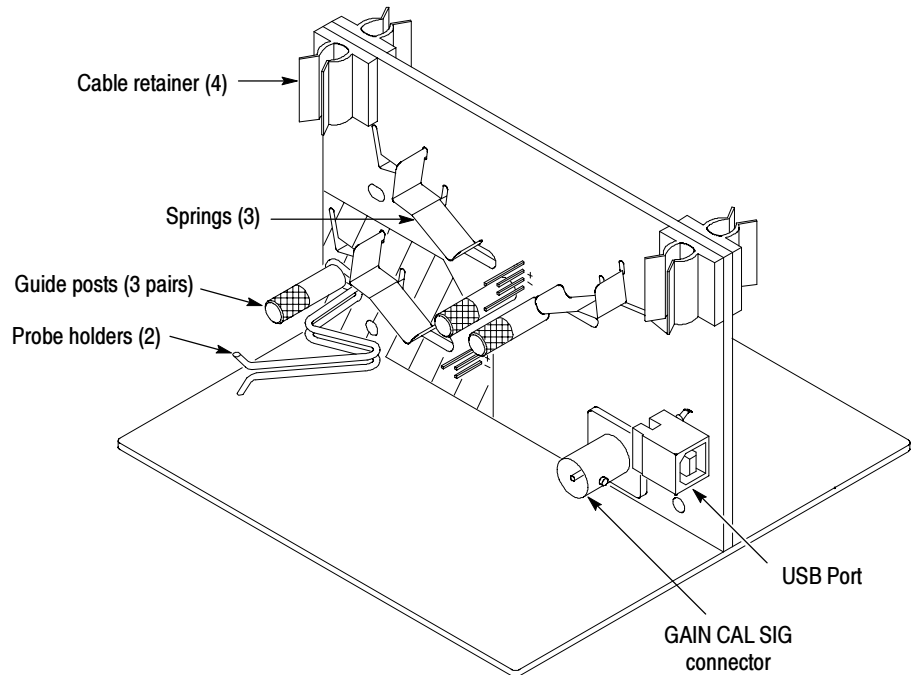

Figure 1: Overview of Deskew Fixture

Overview

This fixture provides an edge source to time align (deskew) and to optimize oscilloscope gain and offset accuracy at the probe tip.

The Deskew Fixture accommodates several Tektronix probes. It has components that aid in the alignment of probes, such as cable retainers, stainless steel springs, guide posts and square pins. The probes are held in place allowing hands-free operation without requiring a probe arm.



CAUTION. Static discharge can damage any semiconductor component on this deskew fixture.

Adhere to the following precautions to avoid damaging internal modules and their components due to electrostatic discharge (ESD).

1. Transport and store the deskew fixture in static protected containers.

2. Discharge the static voltage from your body by wearing a grounded antistatic wrist strap while handling or servicing the deskew fixture. Do service only at a static-free work station.

Specifications

- USB load, ~ 60 mA typical, from the 5 V supply.
- Deskew Fixture output voltage, $V_{ol} \sim 1V$, $V_{oh} \sim 2 V$.
- Deskew Fixture Risetime and frequency, <600 ps, $f = 10$ MHz.
- Gain Cal input and output is less than ± 10 V

Table 1: Certifications and compliances

Category	Standards or description
EC Declaration of Conformity - EMC	<p>Meets intent of Directive 89/336/EEC for Electromagnetic Compatibility. Compliance was demonstrated to the following specifications as listed in the Official Journal of the European Union:</p> <p>EN 61326 1,2,3 EMC requirements for Class A electrical equipment for measurement, control and laboratory use¹</p> <p>EN 61000-3-2 4 AC power line harmonic emissions</p> <p>1 Radiated emissions may exceed the levels specified in EN 61326 when this instrument is connected to a test object.</p> <p>2 Exposed circuitry on the Deskew Fixture may be damaged by electrostatic discharge. IEC 61000-4-2 is not applicable to the circuit board area.</p> <p>3 Immunity performance is dependent on the device supplying power via the USB connection.</p> <p>4 Compliance to EN 61000-3-2 is dependent on the device supplying power via the USB connection. Compliance is assured when powered by a TDS6000 or TDS7000 series instrument.</p>
Australia/New Zealand Declaration of Conformity - EMC	<p>Complies with EMC provision of Radiocommunications Act per the following standard(s):</p> <p>AS/NZS 2064.1/2 Class A limits for Industrial, Scientific, and Medical Equipment: 1992</p>

Powering the Deskew Fixture for Skew Adjust

The Deskew Fixture is powered from a USB port. Using a USB cable (supplied with the fixture) you can connect the fixture to the USB port on the rear panel of the oscilloscope or to a USB port on the Tektronix recommended USB keyboard. You can use an external USB hub or PC.

Connect the Deskew Fixture to a USB power source.

Connecting Probes to the Deskew Fixture



WARNING. To avoid personal injury, use care while connecting probe tips to the square pins on the fixture. The ends of the square pins are sharp.

The Deskew Fixture can be used with several different types of probes, and it accommodates up to six Tektronix probes individually or in combination, (for example, four differential probes with up to two single-ended probes).

Table 2 refers to diagrams that show how to attach a Tektronix probe to the fixture. Refer to the symbols screened on the fixture to establish the correct polarity.

Table 2: Probe deskew connections

Probe	See figures
P6246, P6247, P6248, P6330, P7330	2, 3, 6
P6249	4, 5, 6, 7, 8, 9, 10, 11
P7240	4, 5, 6, 7, 8, 9, 10, 11
P7260	6, 7, 8, 9, 11

NOTE. Be sure that the deskew fixture's pins are straight before use. Take care not to bend the pins.

P6246, P6247, P6248, P6330, P7330

Use this procedure to deskew the P6246, P6247, P6248, P6330, and P7330 differential probes: If single-ended probes are required, go to the next section.

1. Insert the probe cable into the cable retainer.
2. Insert the probe body flush to the board between the adjacent spring and guide post. See Figure 2 on page 4.
3. Slide the probe to allow both probe tips to contact the underside of the SKEW ADJUST positive and negative square pins (middle two pins).

NOTE. Check the markings on the probe body to ensure the positive tip is contacting the positive square pin on the fixture. You can deskew up to four probes of this type with this fixture, two on each side of the board.

4. All probe tips should contact the SKEW ADJUST pins at the center of the probe tips. See Figure 3 on page 5.
5. Set the probe atten switch to 1X position.
6. You can install up to four differential probes using both sides of the Deskew Fixture. You can also install up to two single-ended probes.
7. Proceed to *Using the Deskew Fixture to deskew channels*, page 12.

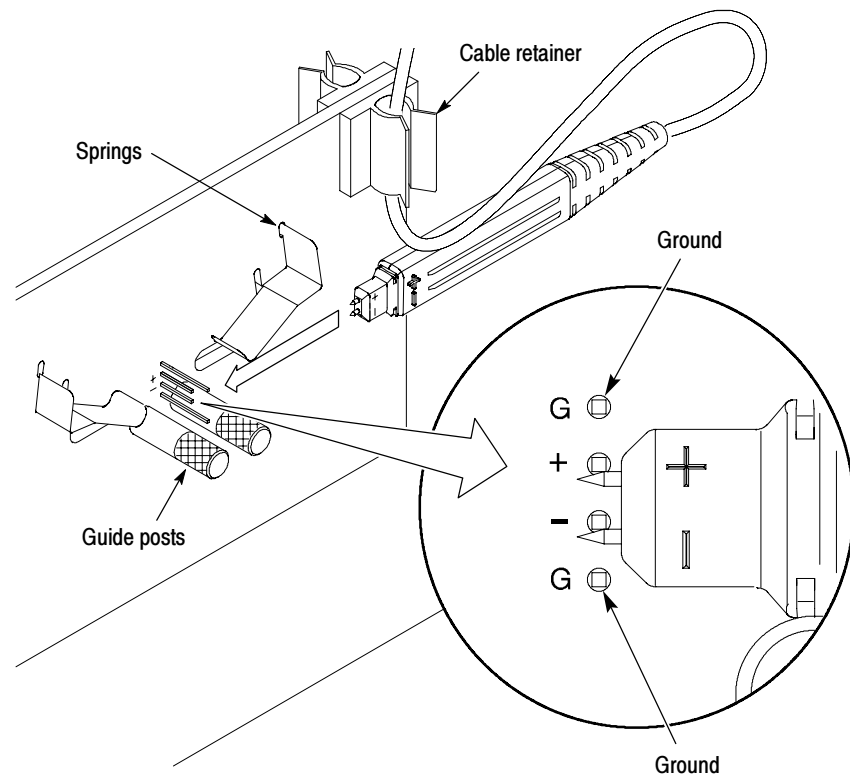

Figure 2: P6246, P6247, P6248, P6330 or P7330 fixture connections

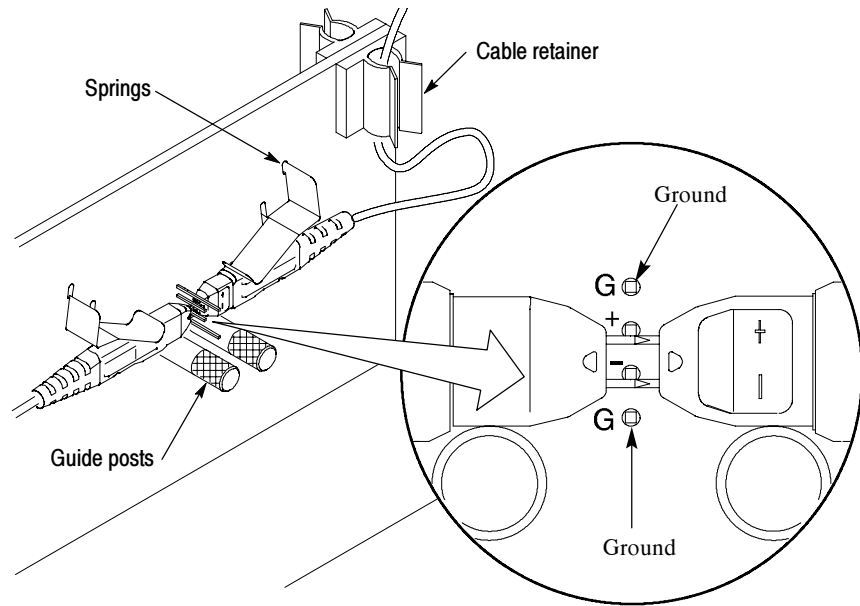

Figure 3: P6246, P6247, P6248, P6330, or P7330 fixture connections

P6249, P7240 without tips

Use this procedure to deskew the P6249 and P7240 single-ended probes without Tektronix probe tips: If single-ended probes with tips are required go to the next section.

1. Remove any probe tips from the probe.
2. Slide the probe over the top of the SKEW ADJUST ground and positive pins. Be sure the probe is perpendicular to the Deskew Fixture. See Figures 4 and 5 on page 6. Repeat this step to add a probe to the other side of the fixture.
3. Proceed to *Using the Deskew Fixture to deskew channels*, page 12.

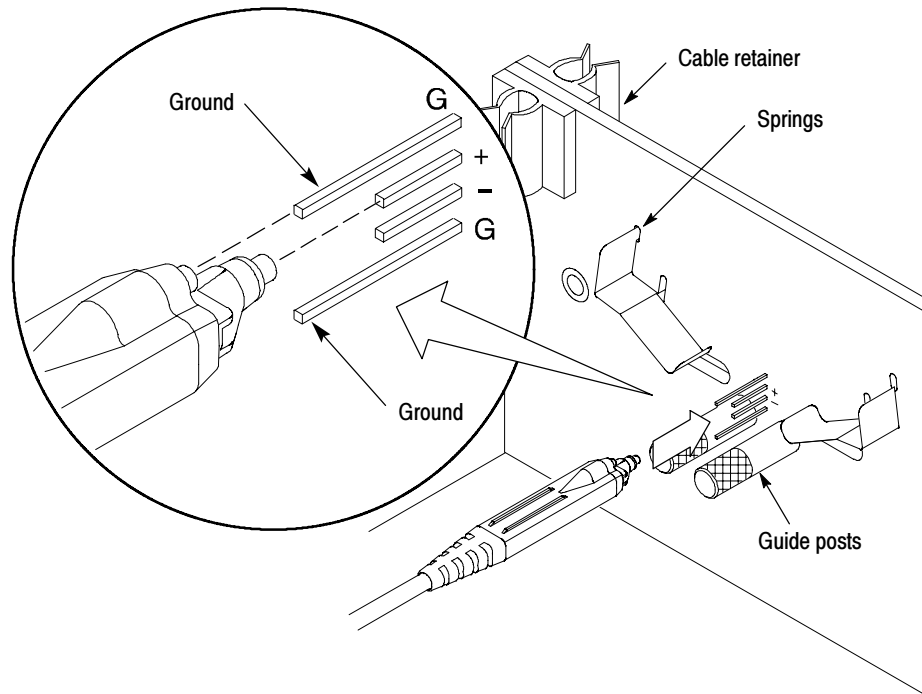

Figure 4: P6249 or P7240 without tips

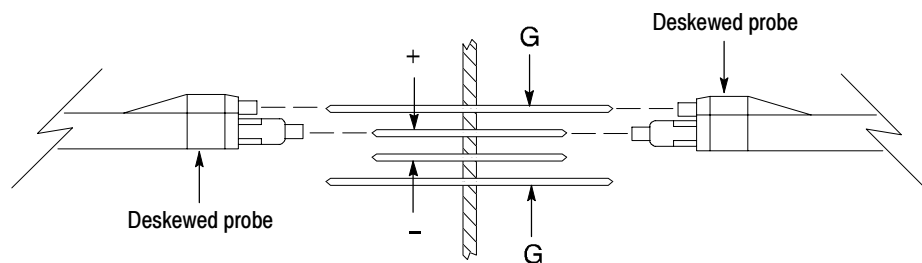

Figure 5: P6249 or P7240 each side of the fixture, without tips

P6249, P7240, P7260 with tips

Use this procedure to deskew P7260 single-ended probe. To deskew P6249 and P7240 single-ended probes install the Tektronix probe tips:

1. Install the guide posts and probe holders to the SKEW ADJUST probe holder position. See Figure 6 on page 8.
2. Secure the probe holders to the deskew fixture by installing the guide posts through the probe holders and into the mounting hole.
3. Slide probe(s) into the probe holder(s) and tighten both guide posts.

4. Position the probe tips to the solder pad locations with the appropriate polarity. See Figures 7 and 8 on page 9.
5. Firmly slide the probes forward until the probe tips make contact with the SKEW ADJUST solder pads.
6. Perform the following procedure to provide probe tip contact pressure with the SKEW ADJUST solder pads: See Figure 9 on page 10.
 - a. Pull back lightly on the probe holder assembly.
 - b. While holding the probe holder assembly back, slide the probe forward until the probe tips stick into the solder pads.
 - c. Now carefully release the probe holder assembly. This will maintain contact pressure.
 - d. Perform substeps a through c for deskewing a second probe. See Figure 8 on page 9.
7. Proceed to *Using the Deskew Fixture to deskew channels*, page 12.

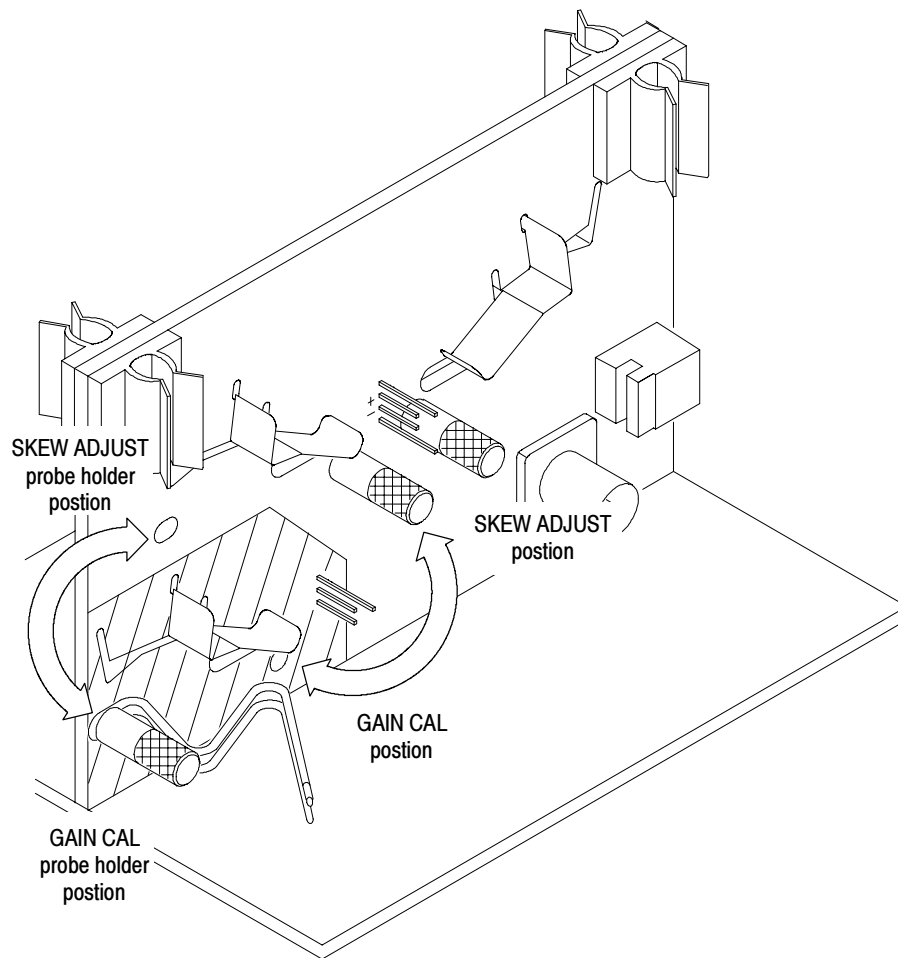

Figure 6: Alternate locations for guide posts and probe holders

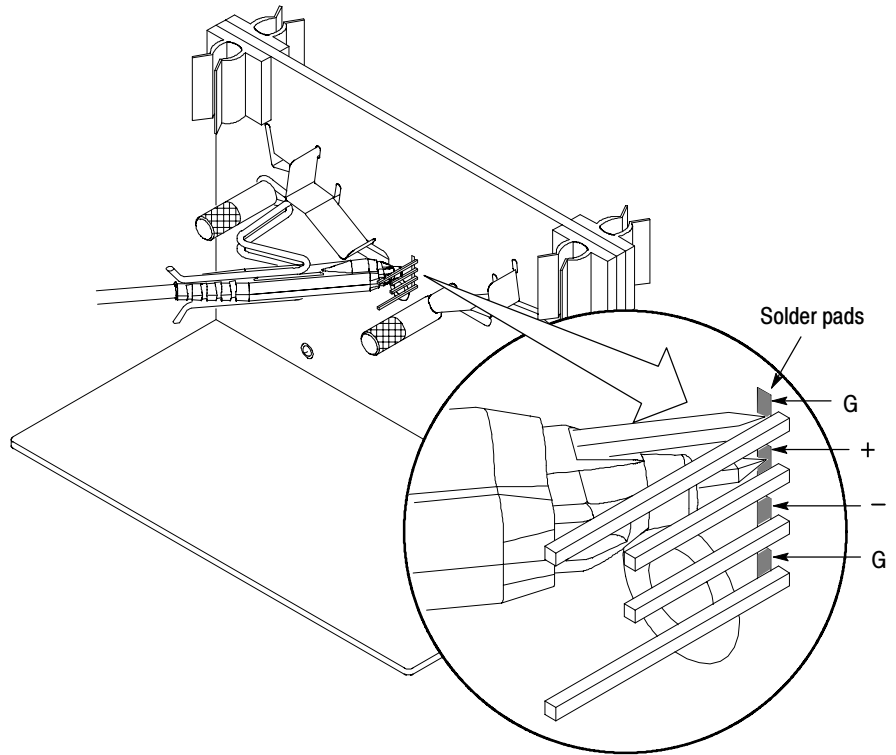

Figure 7: P6249, P7240 or P7260 with tips

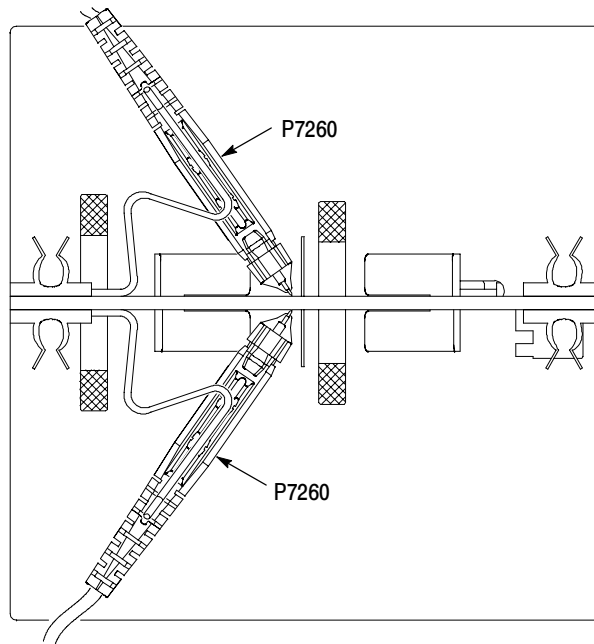

Figure 8: P6249, P7240 or P7260 on each side of the fixture, with tips

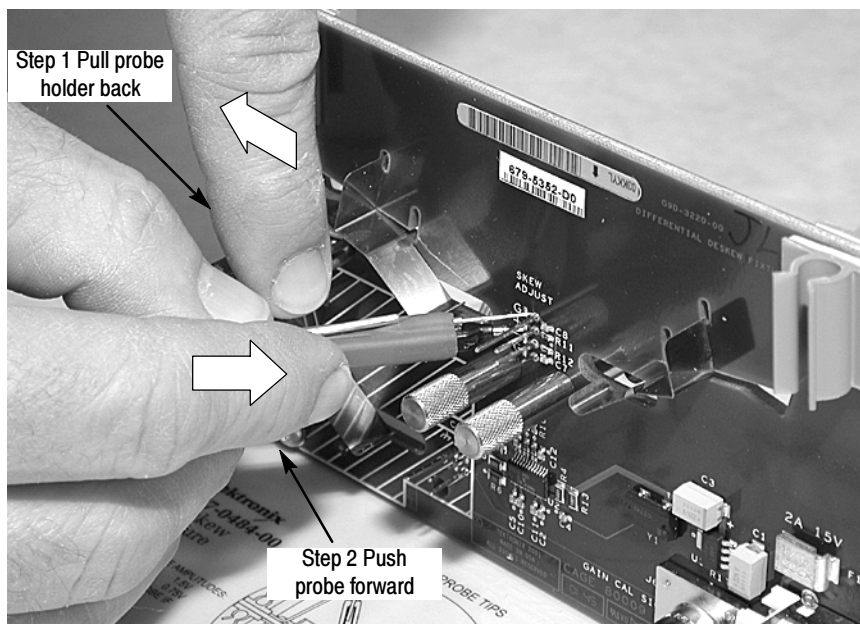

Figure 9: Probe tip contact loading

Load balancing when deskewing a differential probe with a single-ended probe

When deskewing a differential probe with a single-ended probe and to ensure accurate deskewing, an identical single ended probe must be installed onto the deskew pin of opposite polarity to balance the load of the single probe.

1. Install the single-ended probe (load balance probe) to the vacant pins. See Figures 10 and 11 on page 11.
2. The load balance probe does not have to be connected to any test equipment.

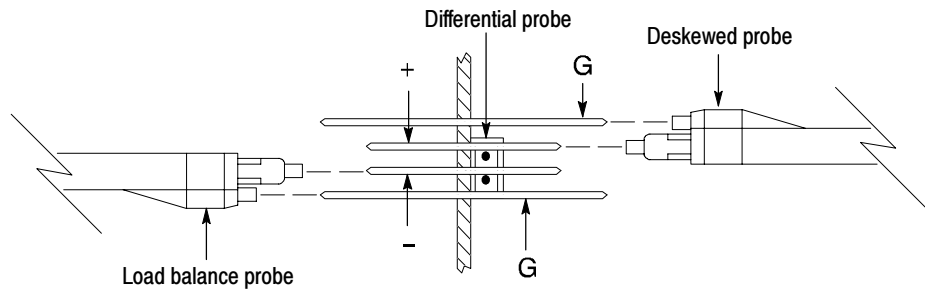

Figure 10: P6249 and P7240 load balance detail without tips

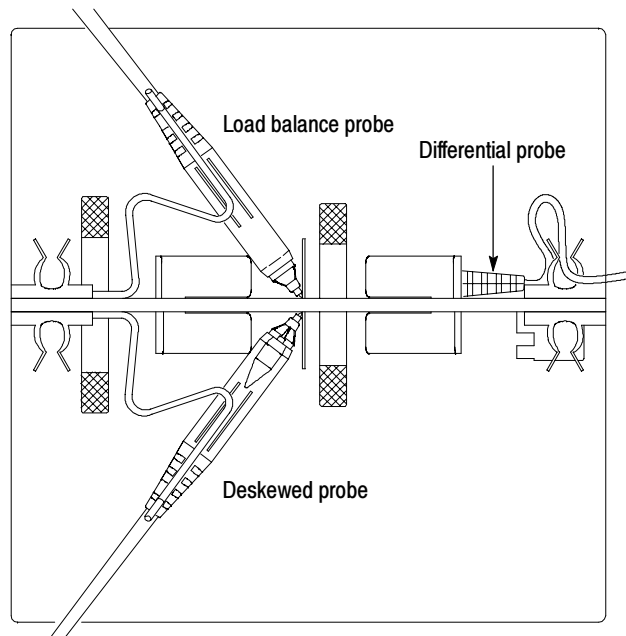

Figure 11: P6249, P7240 or P7260 load balance detail with tips

Using the Deskew Fixture to deskew channels

You can adjust a relative time delay for each channel. This lets you align the signals to compensate for signals that can come in from cables of differing lengths. The oscilloscope's deskew feature applies deskew values after it completes each acquisition; therefore, the deskew values do not affect logic triggering. Also, deskew has no affect on XY and XYZ display formats.

This procedure requires the user to select a common reference channel which all other channels will be deskewed. This is typically Channel 1, but can vary depending on the user's setup.

For best results warm up the oscilloscope for 20 minutes before performing these functions.

1. Connect the probes to the oscilloscope.

When the probes are inserted properly with both tips contacting the correct pins, you will see the following approximate squarewave amplitude: 1500 mV for differential probes; 750 mV for single-ended probes. If you do not see this approximate amplitude, remove the probe and reinsert it or adjust it until the approximate amplitude is achieved. Then, continue with the deskew process.

2. Touch the **Vertical** menu to display the **Deskew** menu.
3. Select Channel **1** and set the Deskew to **0.0s**.
4. Display all channels that you want to deskew, including the reference channel.
5. Push the **AUTOSET** button on the oscilloscope.
6. From the **Horiz/Acq** menu, select **Horizontal/Acquisition Setup**, select **Acquisition** tab, select **Average** and **# of Wfms 16**. Adjust trigger level to get a stable trigger.
7. Adjust the vertical **SCALE** and **POSITION** (with active probes adjusting **offset** can be required) for each channel so that the signals overlap and are centered on screen. It's advised to make sure all channels being deskewed are at the same Volts/div setting. See Figure 12 on page 13.
8. Adjust the horizontal **POSITION** so that a triggered rising edge of the reference channel is at center screen.
9. Adjust the horizontal **SCALE** so that the differences in the channel delays are clearly visible.
10. Adjust the horizontal **POSITION** again so that the reference channel's first rising edge is at center screen.

11. Touch the **Vertical** button menu to display the **Vertical Setup** menu control window.
12. Touch the Probe **Deskew** button to display the channel-deskew control window.
13. Select one of the slower channels.

NOTE. Do the next step at a signal amplitude within the same attenuator range (vertical scale) as your planned signal measurements. Any change to the vertical scale after the deskew is complete can introduce a new attenuation level. A change in the attenuator setting will give a slightly different signal path. This different path can cause as high as 200 ps variation in timing accuracy between channels.

14. Adjust the deskew time for that channel so that its signal aligns with that of the reference channel.
15. Repeat steps 11 and 12 for each additional channel that you want to deskew.

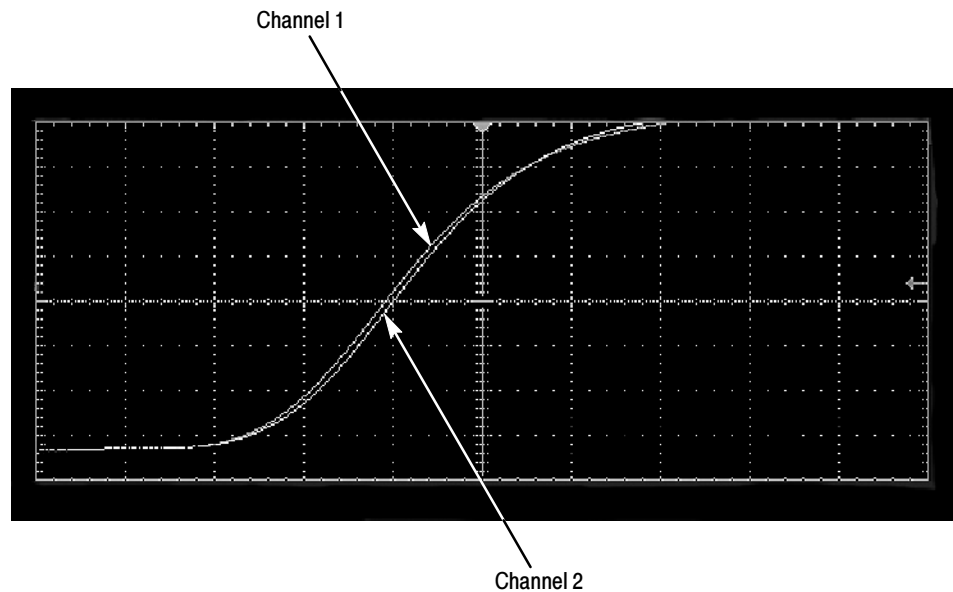

Figure 12: Centering waveforms on the screen

End of procedure

Connecting to the Gain Cal Fixture

Follow these steps to connect the probes and oscilloscope to the fixture.

1. Perform Signal Path Compensation (SPC) before you connect the probes:
 - a. Touch the **Utilities** button to display the **Instrument Calibration** menu.
 - b. Touch the **Instrument Calibration** menu to display the Calibration Instructions menu.
 - c. Touch **Calibrate** to perform the Signal Path Compensation.
2. Connect the oscilloscope PROBE COMPENSATION (PROBE CALIBRATION for the TDS6000B) output to a BNC cable (Tektronix part number 012-0208-00). Connect the remaining end of the BNC cable to the GAIN CAL SIG connector located on the deskew board.
3. Move the guide posts to the GAIN CAL position. See Figure 6 on page 8.
4. Use the probe holders for P6249, P7240 and P7260 with probe tips installed.

Table 3: Probe gain cal connections

Probe	See figures
P6246, P6247, P6248, P6330, P7330	13
P6249, P7240	8, 14, 15
P7260	8, 15

**P6246, P6247, P6248,
P6330, P7330**

Use this procedure to Gain Cal the P6246, P6247, P6248, P6330, and P7330 probes:

1. Insert the probe cable into the cable retainer.
2. Insert the probe body flush to the board between the adjacent spring and guide post. See Figure 13 on page 15.
3. Slide the probe to allow the probe tips to contact the underside of the fixture's signal and ground square pins.
4. Repeat steps 1 through 3 to calibrate a second probe at the same time, one on each side of the fixture.
5. Proceed to the *Using the Deskew Fixture to Gain Cal* on page 18.

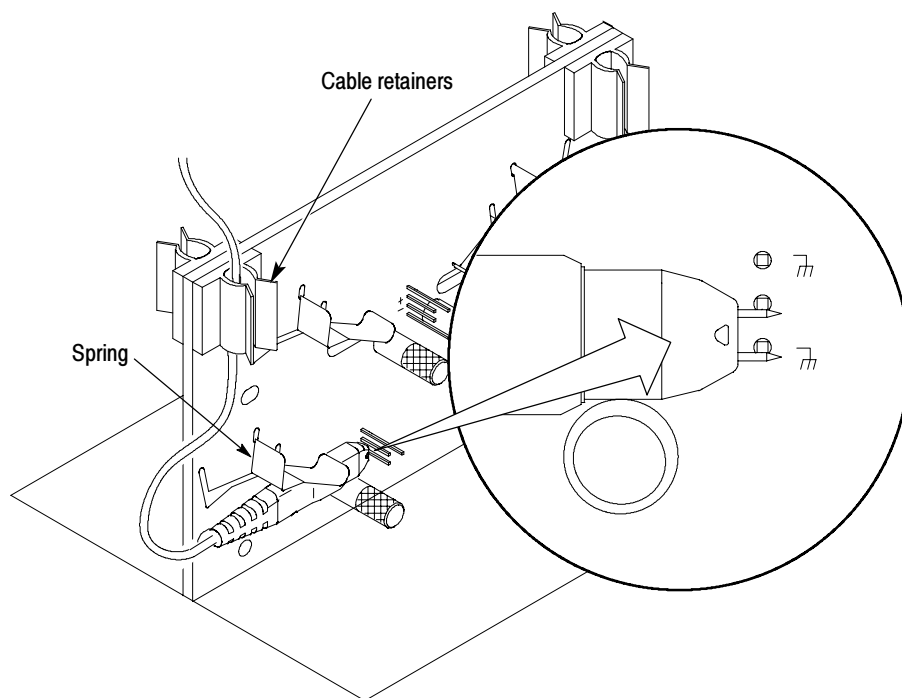

Figure 13: P6246, P6247, P6248, P6330 or P7330 fixture connections

P6249, P7240 without tips

Use this procedure to Gain Cal the P6249 and P7240 probes without Tektronix probe tips:

1. Remove any probe tips from the probe.
2. Slide the probe over the top of the ground and middle GAIN CAL pins. Be sure the probe is perpendicular to the fixture. See Figure 14.
3. Proceed to the *Using the Deskew Fixture to Gain Cal* on page 18.

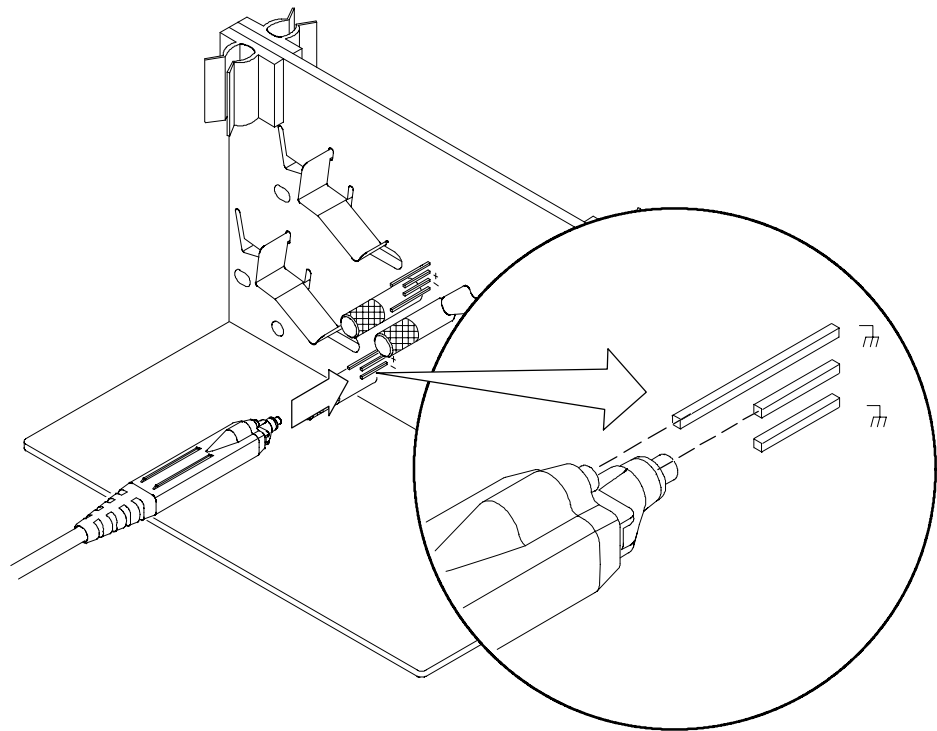

Figure 14: P6249 or P7240 without tips

P6249, P7240, P7260 with tips

Use this procedure to Gain Cal P7260 single-ended probe. To Gain Cal P6249 and P7240 single-ended probes install the Tektronix probe tips:

1. Install the guide posts and probe holders to the GAIN CAL probe holder-position. See Figure 6 on page 8.
2. Secure the probe holders to the GAIN CAL by installing the guide posts through the probe holders and into the mounting hole.
3. Slide probe(s) into the probe holder(s) and tighten both guide posts.

4. Position the probe tips to the solder pad locations with the appropriate polarity. See Figure 15 on page 17.
5. Slide the probe forward until the probe tips make contact with the GAIN CAL solder pads.
6. Perform the following procedure to provide probe tip contact pressure with the GAIN CAL solder pads: See Figure 9 on page 10.
 - a. Pull back lightly on the probe holder assembly.
 - b. While holding the probe holder assembly back, slide the probe forward until the probe tips stick into the GAIN CAL solder pads.
 - c. Now carefully release the probe holder assembly. This will maintain contact pressure.
7. Perform steps 1 through 6 to calibrate a second probe at the same time. See Figure 8 on page 9.
8. Proceed to the *Using the Deskew Fixture to Gain Cal* on page 18.

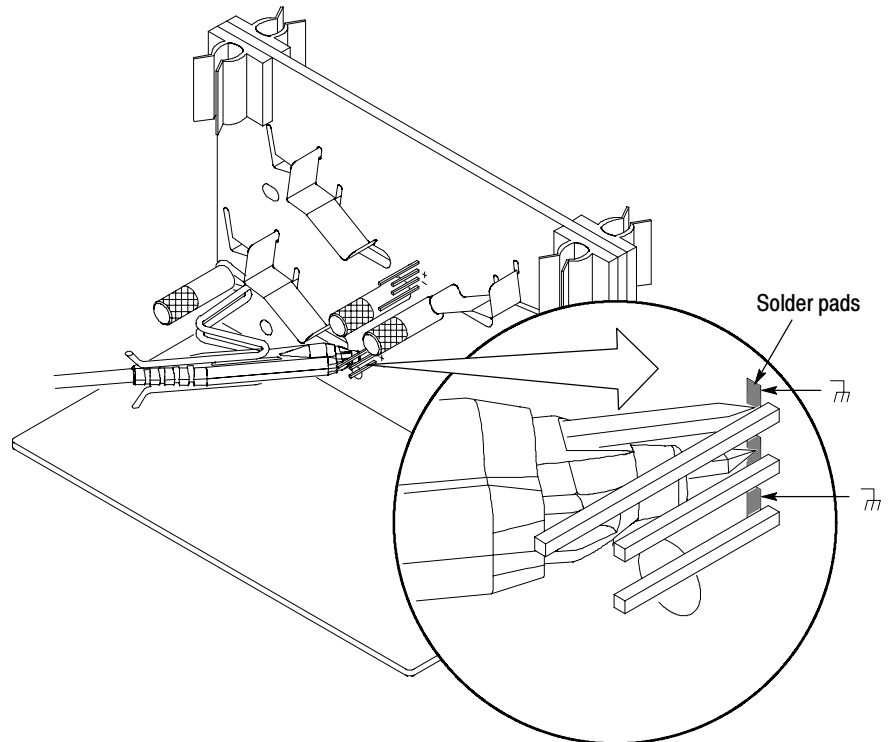

Figure 15: P6249, P7240 or P7260 with tips

Differential and single ended probe Gain Cal

It is possible to perform a Gain Cal using a differential and a single ended probe at the same time.

1. Remove the guide posts from the GAIN CAL position.
2. Substitute the male guide post with a 6-32 screw (not supplied).
3. Install the 6-32 screw on one side of the board and the female guide post with holder on the other side.
4. The side with the 6-32 screw will allow you to gain cal the differential probe.
5. Proceed to the *Using the Deskew Fixture to Gain Cal* on page 18.

Using the Deskew Fixture to Gain Cal

Prior to probe gain calibration the oscilloscope must have had a 20 minute warm up and completed a signal path calibration (SPC) procedure. See page 14.

NOTE. Probes with an attenuation factor of greater than 20X cannot be compensated. Probes with >2% gain errors or >50 mV offset errors cannot be compensated.

NOTE. The USB cable does not need to be connected. GAIN CAL does not require external power.

Optimize gain and offset accuracy

Perform the following procedure to optimize gain and offset accuracy:

1. Connect probe to the oscilloscope.
2. Connect probe to the fixture. See Table 3 on page 14 and *Probe gain cal connections* on page 14.
3. From the tool bar, touch the **Vertical** button to display the oscilloscope **Vertical Setup** control window.
4. Touch the Probe **Cal** button to display the vertical Probe Cal control window.
5. Select the oscilloscope channel to which the probe is attached.
6. Touch **Clear Probecal** to erase any previous calibration data.

7. Touch the **Calibrate Probe** button.
8. When the routine is finished, remove the connections from the deskew fixture.

Check the calibration status

Perform the following procedure to check calibration status:

1. From the tool bar, touch the **Vertical** button to display the oscilloscope **Vertical setup** control window.
2. Touch the Probe **Cal** button to display the vertical Probe Cal control window.
3. Select the oscilloscope channel to which the probe is attached.
4. Check the Probe Status readout:
 - **Initialized:** indicates that the probe has not been calibrated on the selected channel.
 - **Pass:** indicates that the probe has been calibrated on the selected channel.
 - **Fail:** indicates the probe has not been calibrated, repeat gain cal procedures.

NOTE. *Probes without a TekProbe interface cannot be calibrated.*

5. Touch the Help button to access the online assistance.

End of procedure

Mechanical Parts List



CAUTION. *The following is for use only by qualified service personnel. Refer to all Safety Summaries before performing any service.*

This section contains a list of the replaceable modules for the Deskew Fixture. Use this list to identify and order replacement parts.

Abbreviations

Abbreviations conform to American National Standard ANSI Y1.1-1972.

Mfr. Code to Manufacturer Cross Index

The following table cross indexes codes, names, and addresses of manufacturers or vendors of components listed in the parts list.

Manufacturers cross index

Mfr. code	Manufacturer	Address	City, state, zip code
00779	TYCO ELECTRONICS CORP	CUSTOMER SERVICE DEPT P.O. BOX 3608	HARRISBURG, PA 17105-3608
06915	RICHCO	5825 N TRIPP AVE P.O. BOX 804238	CHICAGO, IL 60646
0KB01	STAUFFER SUPPLY CO	810 SE SHERMAN	PORTLAND, OR 97214-4657
0KB05	NORTH STAR NAMEPLATE INC	METAL PRODUCTS 5750 NE MOORE COURT	HILLSBORO, OR 97124-6474
2K262	BOYD CORPORATION	6136 NE 87TH AVENUE	PORTLAND, OR 97220
6D224	FCI USA INC	I/O & CABLE DIVISION 5700 WARLAND DRIVE	CYPRESS, CA 90630
80009	TEKTRONIX INC	14150 SW KARL BRAUN DR PO BOX 500	BEAVERTON, OR 97077-0001
TK0588	UNIVERSAL PRECISION PRODUCT	1775 NW CORNELIUS PASS RD	HILLSBORO, OR 97124
TK0AT	AMP, INC	7-15-14 ROPPOGI MINATO-KU	TOKYO JAPAN,
TK1326	NORTHWEST FOURSLIDE INC	13945 SW GALBREATH DR	SHERWOOD, OR 97140
TK2548	XEROX CORPORATION	7431 NE EVERGREEN PARKWAY, SUITE 130	HILLSBORO, OR 97124

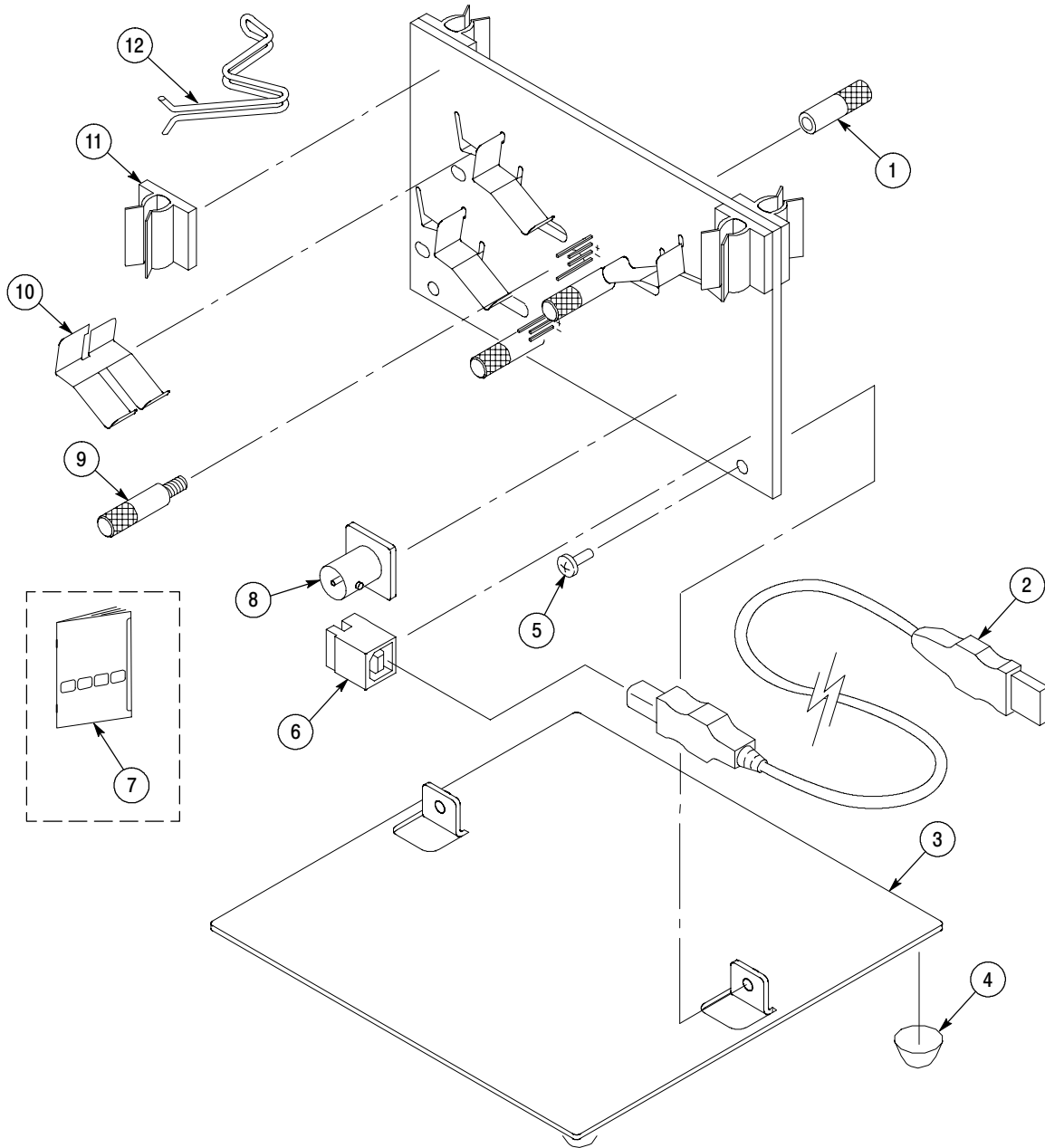

Figure 16: Deskew Fixture

Replaceable Parts List

Fig. & index number	Tektronix part number	Serial no. effective	Serial no. discontinued	Qty	Name & description	Mfr. code	Mfr. part number
Deskew Fixture							
16-1	129-1557-00			3	POST:GUIDE,DESKEW,FEMALE,SMX.IGS,STAINLESS STEEL	TK0588	129-1557-00
-2	174-4401-00			1	CABLE ASSY,I/O:USB, 26 AWG, 3.281 FT, A TO B, MALE	6D224	72380-B100BC
-3	432-0176-00			1	BASE ASSEMBLY:W/LEXAN LABEL,3.0 X 5.50 X 0.175	0KB05	432-0176-00
-4	348-0430-00			4	FOOT:BUMPER,PLASTIC:POLYURETHANE,BLACK	2K262	ORDER BY DESCRIPTION
-5	211-1050-00			2	SCREW,MACHINE:6-32 X 0.312 L,PNH,STL CAD PLT,T15	0KB01	OBD
-6	131-6562-00			1	CONN:PCB,USB SERIES B,FEMALE,RTANG	TK0AT	787780-2
-7	071-7022-01			1	MANUAL,TECH:INSTRUCTION, DESKEW FIXTURE	TK2548	071-7022-01
-8	131-3721-00			1	CONN, RF JACK:BNC SERIES B, FEMALE	00779	227699-2
-9	129-1558-00			3	POST:GUIDE,DESKEW,MALE,SMXGS,STAINLESS STEEL	TK0588	129-1558-00
-10	214-5005-00			3	SPRING:DESKEW,SMX IGS,0.008 SSTL FULL HARD	TK1326	214-5005-00
-11	343-0401-00			4	RETAINER,CABLE:PLASTIC	06915	KKU-4RT
-12	352-1099-00			2	HOLDER, PROBE: DESKEW P6249, P7240,W/tips	80009	352-1099-00

